

Ref. No. D 52000  
Release Date: Oct 03

**CHECK VALVE**  
**CV**

  
www.valsehydraulics.com

**DESCRIPTION**

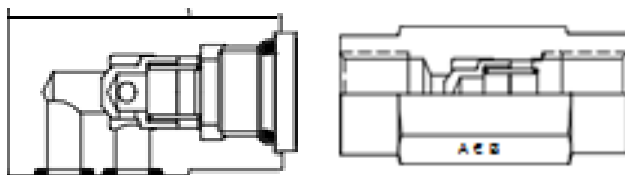

Seat type valves. Allow free flow from Port A to Port B and offer leakage  
Free closure in opposite direction. Two standard mounting styles :  
1) Inline mounting CV\*T

**TECHNICAL SPECIFICATIONS**

Construction ..... Seat type.  
Mounting ..... Inline or subplatemounting.  
Interface ..... Factory standard.  
Mounting position..... Optional.  
Flow direction .....Free flow from A to B.  
Operating pressure ..... 315 bar.  
Hydraulic medium ..... Mineral oil.  
Viscosity range ..... 10 cSt to 380cSt.  
Fluid temperature range..... -20 °C to +70 °C.  
Fluid cleanliness requirement.....As per ISO code 16/13 or better.  
Cracking pressure available..... 0.5, 1.5, 3 or 5 bar.

Size	NG	6	8	10	15	20	25
Nominal flow	l/min	10	20	30	80	120	220
Mass - Inline mounting	Kg	0.1	0.16	0.31	0.46	0.95	1.88
-Sub plate Mounting	Kg	0.27		1		2.8	

**ORDERING CODE**

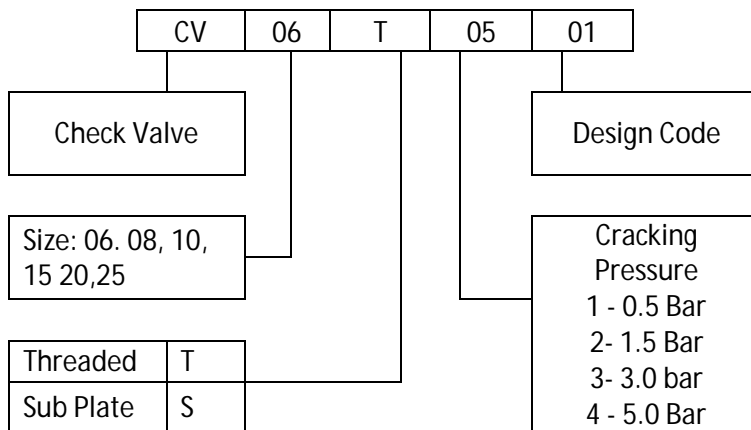

**Valse Fluid Power Private Limited**

**Works:**  
Industrial Estate, Sagar Road,  
Shimoga, Karnataka- 577204 (INDIA)

**Design Center:**  
Industrial Estate, Udyambag  
BELGAUM – 590 008 (INDIA)

**Call / Whatsapp:** +91 984 592 6984  
**Email:** Sales@valsehydraulics.com  
**Website:** www.valsehydraulics.com

UNIT DIMENSIONS

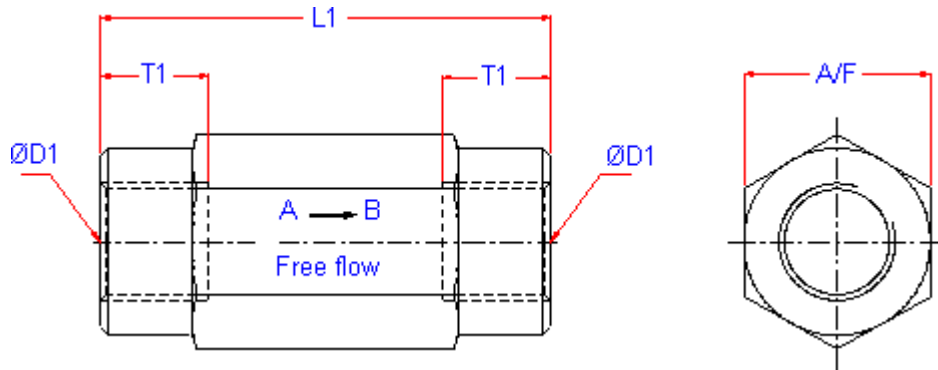

Size	ØD1	L1	T1	A/F
6	G1/4	58	12	19
8	G3/8	58	14	24
10	G1/2	72	14	30
15	G3/4	85	18	36
20	G1	98	18	46
25	G1 1/4	120	20	60

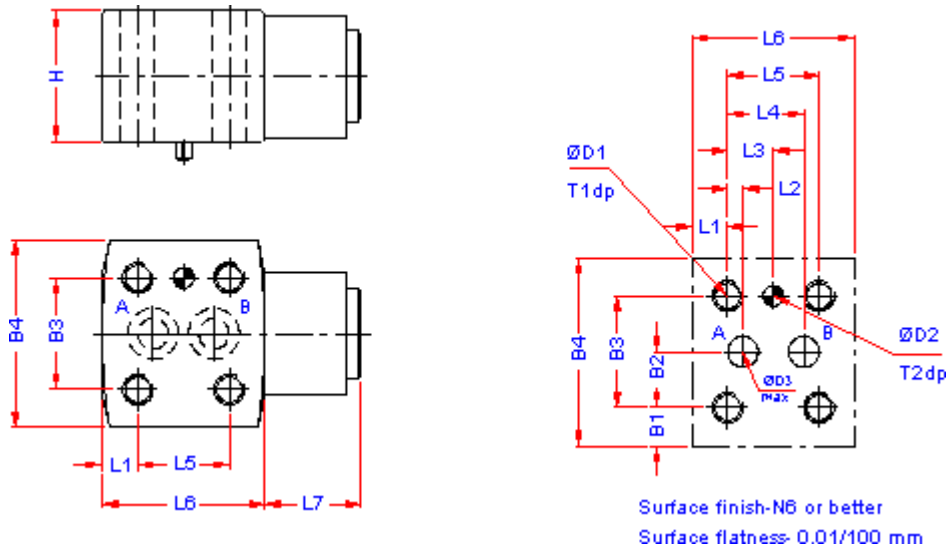

Size NG	L1	L2	L3	L4	L5	L6	L7	H	B1	B2	B3	B4	D1Ø	D2Ø	D3Ø	T1	T2
6	7	3	9	15	18	32	19	26	7.5	11	22	37	M6	4	6	12	5
10	9	6	16.5	27	33	51	23	38	9.5	18	36	55	M8	4	11	14	5
20	10	10	27.5	45	55	75	27	55	10	25	50	70	M10	7	22	19	8

**Valse Fluid Power Private Limited**

**Works:**  
Industrial Estate, Sagar Road,  
Shimoga, Karnataka- 577204 (INDIA)

**Design Center:**  
Industrial Estate, Udyambag  
BELGAUM – 590 008 (INDIA)

**Call / Whatsapp:** +91 984 592 6984  
**Email:** Sales@valsehydraulics.com  
**Website:** www.valsehydraulics.com

